

## BRIDGES AND STRUCTURES

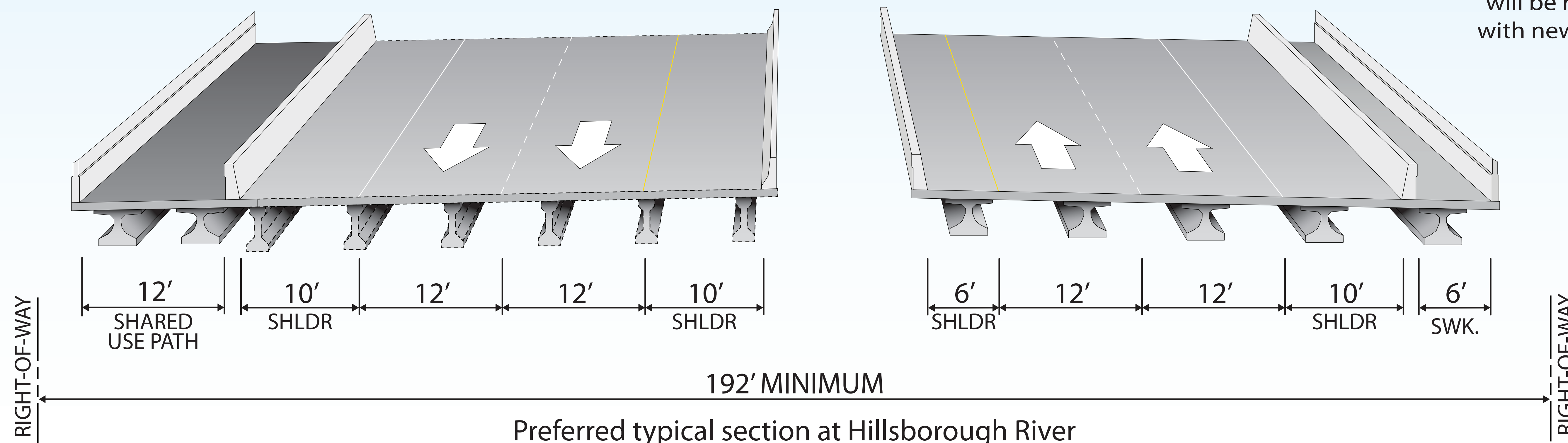
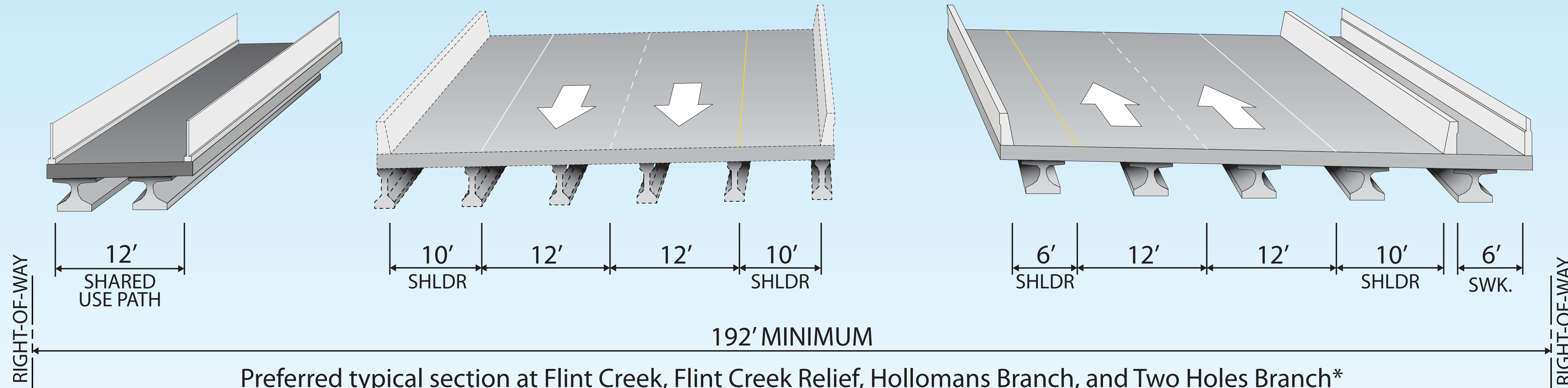

\*Existing box culverts will be replaced with new bridges.